



©2001 Digital Security Controls Ltd.
Toronto, Canada
1-800-387-3630 • www.dsc.com
Printed in Canada 29003579 R004

MAXSYS®

Escort4580 v1.3 • Installation Manual

FCC COMPLIANCE STATEMENT

CAUTION: Changes or modifications not expressly approved by Digital Security Controls Ltd. could void your authority to use this equipment.

This equipment generates and uses radio frequency energy and if not installed and used properly, in strict accordance with the manufacturer's instructions, may cause interference to radio and television reception. It has been type tested and found to comply with the limits for Class B device in accordance with the specifications in Subpart 'B' of Part 15 of FCC Rules, which are designed to provide reasonable protection against such interference in any residential installation. However, there is no guarantee that interference will not occur in a particular installation. If this equipment does cause interference to television or radio reception, which can be determined by turning the equipment off and on, the user is encouraged to try to correct the interference by one or more of the following measures:

- Re-orient the receiving antenna
- Relocate the alarm control with respect to the receiver
- Move the alarm control away from the receiver
- Connect the alarm control into a different outlet so that alarm control and receiver are on different circuits.

If necessary, the user should consult the dealer or an experienced radio/television technician for additional suggestions. The user may find the following booklet prepared by the FCC helpful: 'How to Identify and Resolve Radio/Television Interference Problems.' This booklet is available from the U.S. Government Printing Office, Washington, D.C. 20402, Stock # 004-000-00345-4.

IMPORTANT INFORMATION

NOTIFICATION TO TELEPHONE COMPANY Upon request, the customer shall notify the telephone company of the particular line which the connection will be made, and provide FCC registration number and the ringer equivalence of the protective circuit.

FCC Registration Number: F53CAN-22830-KX-N, Ringer Equivalence Number: 0.0B, USOC Jack: RJ-31X

MALFUNCTION OF THE EQUIPMENT In the event that this equipment should fail to operate properly, the customer shall disconnect the equipment from the telephone line to determine if it is the customer's equipment which is not working properly, or if the problem is with the telephone company network. If the problem is with this equipment, the customer shall discontinue use until it is repaired.

TELEPHONE CONNECTION REQUIREMENTS Except for the telephone company provided ringers, all connections to the telephone network shall be made through standard plugs and telephone company provided jacks, or equivalent, in such a manner as to allow for easy, immediate disconnection of the terminal equipment. Standard jacks shall be so arranged that, if the plug connected there is withdrawn, no interference to the operation of the equipment at the customer's premises which remains connected to the telephone network shall occur by reason of such withdrawal.

INCIDENCE OF HARM Should terminal equipment or protective circuitry cause harm to the telephone network, the telephone company shall, where practicable, notify the customer that temporary disconnection of service may be required; however, where prior notice is not practicable, the telephone company may temporarily discontinue service if such action is deemed reasonable in the circumstances. In the case of such temporary discontinuance, the telephone company shall promptly notify the customer and will be given the opportunity to correct the situation. The customer also has the right to bring a complaint to the FCC if he feels the disconnection is not warranted.

CHANGE IN TELEPHONE COMPANY EQUIPMENT OR FACILITIES The Telephone Company may make changes in its communications facilities, equipment, operations or procedures, where such actions are reasonably required and proper in its business. Should any such changes render the customer's terminal equipment incompatible with the telephone company facilities the customer shall be given adequate notice to the effect of the modifications to maintain uninterrupted service.

GENERAL This equipment should not be used on coin telephone lines. Connection to party line service is subject to state tariffs.

RINGER EQUIVALENCE NUMBER (REN) The REN is useful to determine the quantity of devices that you may connect to your telephone line and still have all of those devices ring when your telephone number is called. In most, but not all areas, the sum of the REN's of all devices connected to one line should not exceed five (5). To be certain of the number of devices that you may connect to your line, you may want to contact your local telephone company.

EQUIPMENT MAINTENANCE FACILITY

Digital Security Controls Ltd. 160 Washburn St. Lockport, NY 14094

WARNING: This manual contains information on limitations regarding product use and function and information on the limitations as to liability of the manufacturer. The entire manual should be carefully read.

WARNING Please Read Carefully

Note to Installers

This warning contains vital information. As the only individual in contact with system users, it is your responsibility to bring each item in this warning to the attention of the users of this system.

System Failures

This system has been carefully designed to be as effective as possible. There are circumstances, however, involving fire, burglary, or other types of emergencies where it may not provide protection. Any alarm system of any type may be compromised deliberately or may fail to operate as expected for a variety of reasons. Some but not all of these reasons may be:

■ Inadequate Installation

A security system must be installed properly in order to provide adequate protection. Every installation should be evaluated by a security professional to ensure that all access points and areas are covered. Locks and latches on windows and doors must be secure and operate as intended. Windows, doors, walls, ceilings and other building materials must be of sufficient strength and construction to provide the level of protection expected. A reevaluation must be done during and after any construction activity. An evaluation by the fire and/or police department is highly recommended if this service is available.

■ Criminal Knowledge

This system contains security features which were known to be effective at the time of manufacture. It is possible for persons with criminal intent to develop techniques which reduce the effectiveness of these features. It is important that a security system be reviewed periodically to ensure that its features remain effective and that it be updated or replaced if it is found that it does not provide the protection expected.

■ Access by Intruders

Intruders may enter through an unprotected access point, circumvent a sensing device, evade detection by moving through an area of insufficient coverage, disconnect a warning device, or interfere with or prevent the proper operation of the system.

■ Power Failure

Control units, intrusion detectors, smoke detectors and many other security devices require an adequate power supply for proper operation. If a device operates from batteries, it is possible for the batteries to fail. Even if the batteries have not failed, they must be charged, in good condition and installed correctly. If a device operates only by AC power, any interruption, however brief, will render that device inoperative while it does not have power. Power interruptions of any length are often accompanied by voltage fluctuations which may damage electronic equipment such as a security system. After a power interruption has occurred, immediately conduct a complete system test to ensure that the system operates as intended.

■ Failure of Replaceable Batteries

This system's wireless transmitters have been designed to provide several years of battery life under normal conditions. The expected battery life is a function of the device environment, usage and type. Ambient conditions such as high humidity, high or low temperatures, or large temperature fluctuations may reduce the expected battery life. While each transmitting device has a low battery monitor which identifies when the batteries need to be replaced, this monitor may fail to operate as expected. Regular testing and maintenance will keep the system in good operating condition.

■ Compromise of Radio Frequency (Wireless) Devices

Signals may not reach the receiver under all circumstances which could include metal objects placed on or near the radio path or deliberate jamming or other inadvertent radio signal interference.

■ System Users

A user may not be able to operate a panic or emergency switch possibly due to permanent or temporary physical disability, inability to reach the device in time, or unfamiliarity with the correct operation. It is important that all system users be trained in the correct operation of the alarm system and that they know how to respond when the system indicates an alarm.

■ Smoke Detectors

Smoke detectors that are a part of this system may not properly alert occupants of a fire for a number of reasons, some of which follow. The smoke detectors may have been improperly installed or positioned. Smoke may not be able to reach the smoke detectors, such as when the fire is in a chimney, walls or roofs, or on the other side of closed doors. Smoke detectors may not detect smoke from fires

on another level of the residence or building.

Every fire is different in the amount of smoke produced and the rate of burning. Smoke detectors cannot sense all types of fires equally well. Smoke detectors may not provide timely warning of fires caused by carelessness or safety hazards such as smoking in bed, violent explosions, escaping gas, improper storage of flammable materials, overloaded electrical circuits, children playing with matches or arson.

Even if the smoke detector operates as intended, there may be circumstances when there is insufficient warning to allow all occupants to escape in time to avoid injury or death.

■ Motion Detectors

Motion detectors can only detect motion within the designated areas as shown in their respective installation instructions. They cannot discriminate between intruders and intended occupants. Motion detectors do not provide volumetric area protection. They have multiple beams of detection and motion can only be detected in unobstructed areas covered by these beams. They cannot detect motion which occurs behind walls, ceilings, floor, closed doors, glass partitions, glass doors or windows. Any type of tampering whether intentional or unintentional such as masking, painting, or spraying of any material on the lenses, mirrors, windows or any other part of the detection system will impair its proper operation.

Passive infrared motion detectors operate by sensing changes in temperature. However their effectiveness can be reduced when the ambient temperature rises near or above body temperature or if there are intentional or unintentional sources of heat in or near the detection area. Some of these heat sources could be heaters, radiators, stoves, barbecues, fireplaces, sunlight, steam vents, lighting and so on.

■ Warning Devices

Warning devices such as sirens, bells, horns, or strobes may not warn people or waken someone sleeping if there is an intervening wall or door. If warning devices are located on a different level of the residence or premise, then it is less likely that the occupants will be alerted or awakened. Audible warning devices may be interfered with by other noise sources such as stereos, radios, televisions, air conditioners or other appliances, or passing traffic. Audible warning devices, however loud, may not be heard by a hearing-impaired person.

■ Telephone Lines

If telephone lines are used to transmit alarms, they may be out of service or busy for certain periods of time. Also an intruder may cut the telephone line or defeat its operation by more sophisticated means which may be difficult to detect.

■ Insufficient Time

There may be circumstances when the system will operate as intended, yet the occupants will not be protected from the emergency due to their inability to respond to the warnings in a timely manner. If the system is monitored, the response may not occur in time to protect the occupants or their belongings.

■ Component Failure

Although every effort has been made to make this system as reliable as possible, the system may fail to function as intended due to the failure of a component.

■ Inadequate Testing

Most problems that would prevent an alarm system from operating as intended can be found by regular testing and maintenance. The complete system should be tested weekly and immediately after a break-in, an attempted break-in, a fire, a storm, an earthquake, an accident, or any kind of construction activity inside or outside the premises. The testing should include all sensing devices, keypads, consoles, alarm indicating devices and any other operational devices that are part of the system.

■ Security and Insurance

Regardless of its capabilities, an alarm system is not a substitute for property or life insurance. An alarm system also is not a substitute for property owners, renters, or other occupants to act prudently to prevent or minimize the harmful effects of an emergency situation.

LIMITED WARRANTY

Digital Security Controls Ltd. warrants the original purchaser that for a period of twelve months from the date of purchase, the product shall be free of defects in materials and workmanship under normal use. During the warranty period, Digital Security Controls Ltd. shall, at its option, repair or replace any defective product upon return of the product to its factory, at no charge for labour and materials. Any replacement and/or repaired parts are warranted for the remainder of the original warranty or ninety (90) days, whichever is longer. The original purchaser must promptly notify Digital Security Controls Ltd. in writing that there is defect in material or workmanship, such written notice to be received in all events prior to expiration of the warranty period. There is absolutely no warranty on software and all software products are sold as a user license under the terms of the software license agreement included with the product. The Customer assumes all responsibility for the proper selection, installation, operation and maintenance of any products purchased from DSC. Custom products are only warranted to the extent that they do not function upon delivery. In such cases, DSC can replace or credit at its option.

International Warranty

The warranty for international customers is the same as for any customer within Canada and the United States, with the exception that Digital Security Controls Ltd. shall not be responsible for any customs fees, taxes, or VAT that may be due.

Warranty Procedure

To obtain service under this warranty, please return the item(s) in question to the point of purchase. All authorized distributors and dealers have a warranty program. Anyone returning goods to Digital Security Controls Ltd. must first obtain an authorization number. Digital Security Controls Ltd. will not accept any shipment whatsoever for which prior authorization has not been obtained.

Conditions to Void Warranty

This warranty applies only to defects in parts and workmanship relating to normal use. It does not cover:

- damage incurred in shipping or handling;
- damage caused by disaster such as fire, flood, wind, earthquake or lightning;
- damage due to causes beyond the control of Digital Security Controls Ltd. such as excessive voltage, mechanical shock or water damage;
- damage caused by unauthorized attachment, alterations, modifications or foreign objects;
- damage caused by peripherals (unless such peripherals were supplied by Digital Security Controls Ltd.);
- defects caused by failure to provide a suitable installation environment for the products;
- damage caused by use of the products for purposes other than those for which it was designed;
- damage from improper maintenance;
- damage arising out of any other abuse, mishandling or improper application of the products.

Items Not Covered by Warranty

In addition to the items which void the Warranty, the following items shall not be covered by Warranty: (i) freight cost to the repair centre; (ii) products which are not identified with DSC's product label and lot number or serial number; (iii) products disassembled or repaired in such a manner as to adversely affect performance or prevent adequate inspection or testing to verify any warranty claim. Access cards or tags returned for replacement under warranty will be credited or replaced at DSC's option.

Products not covered by this warranty, or otherwise out of warranty due to age, misuse, or damage shall be evaluated, and a repair estimate shall be provided. No repair work will be performed until a valid purchase order is received from the Customer and a Return Merchandise Authorisation number (RMA) is issued by DSC's Customer Service.

Digital Security Controls Ltd.'s liability for failure to repair the product under this warranty after a reasonable number of attempts will be limited to a replacement of the product, as the exclusive remedy for breach of warranty. Under no circumstances shall Digital Security Controls Ltd. be liable for any special, incidental, or consequential damages based upon breach of warranty, breach of contract, negligence, strict liability, or any other legal theory. Such damages include, but are not limited to, loss of profits, loss of the product or any associated equipment, cost of capital, cost of substitute or replacement equipment, facilities or services, down time, purchaser's time, the claims of third parties, including customers, and injury to property. The laws of some jurisdictions limit or do not allow the disclaimer of consequential damages. If the laws of such a jurisdiction apply to any claim by or against DSC, the limitations and disclaimers contained here shall be to the greatest extent permitted by law. Some states do not allow the exclusion or limitation of incidental or consequential damages, so that the above may not apply to you.

Disclaimer of Warranties

This warranty contains the entire warranty and shall be in lieu of any and all other warranties, whether expressed or implied (including all implied warranties of merchantability or fitness for a particular purpose) and of all other obligations or liabilities on the part of Digital Security Controls Ltd. Digital Security Controls Ltd. neither assumes responsibility for nor authorizes any other person purporting to act on its behalf to modify or to change this warranty, nor to assume for it any other warranty or liability concerning this product.

This disclaimer of warranties and limited warranty are governed by the laws of the province of Ontario, Canada.

WARNING: Digital Security Controls Ltd. recommends that the entire system be completely tested on a regular basis. However, despite frequent testing, and due to, but not limited to, criminal tampering or electrical disruption, it is possible for this product to fail to perform as expected.

Out of Warranty Repairs

Digital Security Controls Ltd. will at its option repair or replace out-of-warranty products which are returned to its factory according to the following conditions. Anyone returning goods to Digital Security Controls Ltd. must first obtain an authorization number. Digital Security Controls Ltd. will not accept any shipment whatsoever for which prior authorization has not been obtained.

Products which Digital Security Controls Ltd. determines to be repairable will be repaired and returned. A set fee which Digital Security Controls Ltd. has predetermined and which may be revised from time to time, will be charged for each unit repaired.

Products which Digital Security Controls Ltd. determines not to be repairable will be replaced by the nearest equivalent product available at that time. The current market price of the replacement product will be charged for each replacement unit.

Special Programming

S e c t i o n 9

[999] Reset to Factory Default Settings

To reset the Escort4580 to the factory default programming, enter [*][8][Service Code][999]. The system will prompt

'Enter the Service Code'

Enter the service code. The system will prompt

'Enter the Section Number'

Enter [999]. The system will then prompt

'Factory Default in Progress'

When the system reset is complete, the system will prompt

'Factory Default is Complete'

NOTE: The Escort4580 may also be reset using the PC4020 Escort4580 Default function. Refer to the PC4020 Installation Manual for additional information.

Programming Audio (User) Help

If you connect an audio interface module (PC4936 and intercom stations) to the security system, the Escort4580 can provide step-by-step audio instructions to users through the intercom stations.

To set up this feature, program one of the keypad function keys for User Help. When a user presses this key, the Escort4580 will broadcast voice prompted user help over the closest intercom station. No Escort4580 programming is required for this feature to work.

Refer to your system's *Installation Manual* and the PC4936 *Installation Manual* for more information.

NOTE: If a user is accessing the Escort4580 locally over the telephone line, the Help function key will not work.

NOTICE: The Industry Canada label identifies certified equipment. This certification means that the equipment meets certain telecommunications network protective, operational and safety requirements. Industry Canada does not guarantee the equipment will operate to the user's satisfaction.

Before installing this equipment, users should ensure that it is permissible to be connected to the facilities of the local telecommunications company. The equipment must also be installed using an acceptable method of connection. The customer should be aware that compliance with the above conditions may not prevent degradation of service in some situations.

Repairs to certified equipment should be made by an authorized Canadian maintenance facility designated by the supplier. Any repairs or alterations made by the user to this equipment, or equipment malfunctions, may give the telecommunications company cause to request the user to disconnect the equipment.

User should ensure for their own protection that the electrical ground connections of the power utility, telephone lines and internal metallic water pipe system, if present, are connected together. This precaution may be particularly important in rural areas.

CAUTION: Users should not attempt to make such connections themselves, but should contact the appropriate electric inspection authority, or electrician, as appropriate.

The Load Number (LN) assigned to each terminal device denotes the percentage of the total load to be connected to a telephone loop which is used by the device, to prevent overloading. The termination on a loop may consist of any combination of devices subject only to the requirement that the total of the Load Numbers of all the devices does not exceed 100.

The Load Number of this unit is 2.

AVIS: L'étiquette de l'Industrie Canada identifie le matériel homologué. Cette étiquette certifie que le matériel est conforme à certaines normes de protection, d'exploitation et de sécurité des réseaux de télécommunications. Industrie Canada n'assure toutefois pas que le matériel fonctionnera à la satisfaction de l'utilisateur.

Avant d'installer ce matériel, l'utilisateur doit s'assurer qu'il est permis de le raccorder aux installations de l'entreprise locale de télécommunication. Le matériel doit également être installé en suivant une méthode acceptée de raccordement. L'abonné ne doit pas oublier qu'il est possible que la conformité aux conditions énoncées ci-dessus n'empêchent pas la dégradation du service dans certaines situations.

Les réparations de matériel homologué doivent être effectuées par un centre d'entretien canadien autorisé désigné par le fournisseur. La compagnie de télécommunications peut demander à l'utilisateur de débrancher un appareil à la suite de réparations ou de modifications effectuées par l'utilisateur ou à cause de mauvais fonctionnement.

Pour sa propre protection, l'utilisateur doit s'assurer que tous les fils de mise à la terre de la source d'énergie électrique, les lignes téléphoniques et les canalisations d'eau métalliques, s'il y en a, sont raccordés ensemble. Cette précaution est particulièrement importante dans les régions rurales.

AVERTISSEMENT: L'utilisateur ne doit pas tenter de faire ces raccordements lui-même; il doit avoir recours à un service d'inspection des installations électriques, ou à un électricien, selon le cas.

L'indice de charge (IC) assigné à chaque dispositif terminal indique, pour éviter toute surcharge, le pourcentage de la charge totale qui peut être raccordée à un circuit téléphonique bouclé utilisé par ce dispositif. La terminaison du circuit bouclé peut être constituée de n'importe quelle combinaison de dispositifs, pourvu que la somme des indices de charge de l'ensemble des dispositifs ne dépasse pas 100.

L'Indice de charge de ce produit est 2.

Table of Contents

Hook-Up Diagram	ii
Introduction	1
Features	1
Specifications	1
Installation	2
Mounting the Cabinet	2
Wiring	2
Programming	3
Programming Data Entry Sections	3
Programming Toggle Option Sections	4
Programming Label Entry Sections	4
System Programming	5
[001] Service Code	5
[002] First System Option Code	5
[003] Status Prompt Mask	5
[004] [*] Function Prompt Mask	6
[005] Local Programming Lockout Counter	6
[006] Local Programming Lockout Duration	6
[007] Number of Home Automation Transmissions	6
[010] - [017] Output Control Prompt Masks By Partition	6
Telephone Access Programming	7
[020] Local and Remote Telephone Access Code	7
[021] Telephone Access Options	7
Automation Schedules	8
[030] Schedule 1 ON Time	8
[031] Schedule 1 OFF Time	8
[032] Schedule 1 Day Mask	8
Automation Items	9
[130] Automation Item 1: House Code and Unit Number	9
[131] Automation Item 1: Miscellaneous Options	9
[132] Automation Item 1: Schedule Assignment	11
[133] Automation Item 1: Mode Assignment	11
[134] Automation Item 1: Schedule / Output Condition	11
Assigning Items to Programmable Outputs	12
Automation Item Pulse Timers	12
Label Programming	13
Adding Numbers to Labels	13
[451] through [482]: Automation Item Labels	13
[521] through [528]: Automation Mode Labels	13
[561] through [568]: System Partition Labels	13
[601] through [728]: System Zone Labels	13
[801] through [864]: Output Control Labels	13
Special Programming	14
[999] Reset to Factory Default Settings	14
Programming Audio (User) Help	14

Hook-Up Diagram

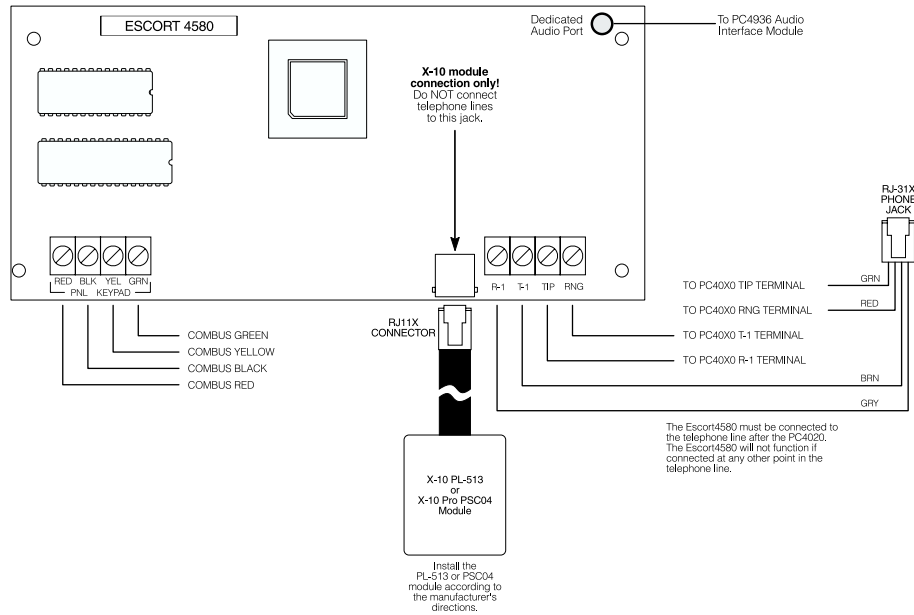

NOTE: If there is a PC4936 on the system, connect the modules to the telephone line as shown below.

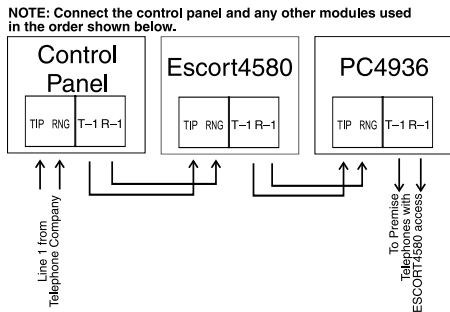

Label Programming

S e c t i o n 8

Program the voice prompt labels for the following in programming sections [451] through [864]:

- Automation Items
- Automation Modes
- Partitions
- Zones
- Output Controls

Each label can have up to 6 words, except for zone labels which can have up to eight words. Refer to *Programming Worksheets* Appendix B, "Word Library" for a list of available words. Program a word into a label by entering the word's 3-digit code in the label's programming section. Refer to section 3, "Programming" for general label programming instructions.

Adding Numbers to Labels

Three special number commands are available to allow the system to include a number in the voice label. The number commands allow the system to announce the number in three different modes:

Label 000: Number Command 1, Combined Form. The number will be announced in its full form. For example, the number 401 would be announced as **'four hundred and one'**.

Label 001: Number Command 2, Ordered Form. The number will be announced in a descriptive form. For example, the number 401 would be announced as **'four hundred and first'**.

Label 002: Number Command 3, Individual Numbers. Each digit in the number will be announced individually. For example, the number 401 would be announced as **'four zero one'**.

The number commands take up two of the six available word spaces in a label. In the first space select the type of announcement for the number (Number Command 000, 001 or 002). In the second space program the 3-digit number to be read (from 000 to 999).

NOTE: Because number commands take up 2 label spaces, you cannot program them in the sixth entry spot for a label.

[451] through [482]:

Automation Item Labels

Enter up to six 3-digit label codes for the labels for automation items 01 through 32. Record the label in the appropriate section of the *Programming Worksheets*.

[521] through [528]:

Automation Mode Labels

Enter up to six 3-digit label codes for the labels for automation modes 1 through 8. Record the label in the appropriate section of the *Programming Worksheets*.

[561] through [568]:

System Partition Labels

Enter up to six 3-digit label codes for the labels for partitions 1 through 8. Record the label in the appropriate section of the *Programming Worksheets*.

[601] through [728]:

System Zone Labels

Enter up to eight 3-digit label codes for the labels for zones 001 through 128.

NOTE: The first two words in the label will only be announced when the zone is in alarm. If the first two words will not be used, program them each as [245] (2-second pause).

Record the label in the appropriate section of the *Programming Worksheets*.

[801] through [864]: Output

Control Labels

Enter up to six 3-digit label codes for the labels for output controls 1-8 in partitions 1-8. Record the label in the appropriate section of the *Programming Worksheets*.

Introduction

S e c t i o n 1

(03) Follows Schedule or Programmable Output: The item activates when its assigned schedules and assigned mode is active. The item will also activate when its assigned programmable output is active. If the schedules and the output are active at the same time, the item will also be active. See '*Schedule Assignment*' and '*Assigning Items to Programmable Outputs*'.

Example: Item 1 controls a light. Item 1 is assigned to schedule 3, which activates at 19:00 and de-activates at 22:00 every day and programmable output option (07) Inverted Arm Status. Any time the system is disarmed, the light will be on. The light will also be on between 7:00pm and 10:00pm every day. If the system is *armed* between 7:00pm and 10:00pm, the light *will turn on*.

(04) Follows Schedule and Programmable Output: The item activates only when its assigned schedules are active at the same time as the assigned programmable output is active. See '*Schedule Assignment*' and '*Assigning Items to Programmable Outputs*'.

Example: Item 1 controls a light. Item 1 is assigned to schedule 3, which activates at 19:00 and de-activates at 22:00 every day and programmable output option (07) Inverted Arm Status. If the system is disarmed between 7:00pm and 10:00pm, the light will be on during that time. If the system is *armed* between 7:00pm and 10:00pm, the light will *not* turn on.

NOTE: Program Automation Items 2 through 32 in sections [135] - [289] in the same manner as Automation Item 1 (refer to sections [130]-[134] and the Programming Worksheets for programming instructions).

Assigning Items to Programmable Outputs

You can assign an automation item to follow a programmable output option.

For example, if you assign item 1 to programmable output option (38) Command Output 1, the item will activate or deactivate whenever the user activates the command output (e.g. using [*][7][1]).

Please refer to the PC4020 *Installation Manual* for a complete description of available programmable output options.

To assign an item to a programmable output option:

1. At any system keypad, enter [*][8][Installer Code]. This takes you into the PC4020 Installer Programming sections.
2. Enter reference number [000705]. (Refer to your PC4020 *Installation Manual* for instructions on using reference numbers.)
3. Enter the 2-digit number of the automation item you want to program (01-32).
4. Enter the 2-digit number of the programmable output option you want the item to follow (00-58). Record your programming choices in the *Escort4580 Programming Worksheets*.
5. To save your programming and exit the section, press [#].

NOTE: Please see section 8, 'Label Programming' for a description of programming output control labels for programmable output options (38)-(45) Command Outputs 1-8.

Automation Item Pulse Timers

You can program pulse times for automation items 01 to 32 in programming sections [301] to [332]. Valid entries are 001 to 255 seconds.

You can enable the Automation Pulse Times by turning OFF option 06 in the 'Miscellaneous Options' section for the automation item (refer to programming section [131] for more information).

Features

- Allows the Maxsys PC4020 security systems to be operated through local and remote Touch-Tone* telephones

NOTE: *The Escort4580 cannot be used with PC4020CF panels.*

- Voice prompt operation
- Informative prompts guide the user through all system functions selected as being accessible through the Escort4580
- Programmable voice labels for zones, partitions and functions
- Adds home automation to the PC4020, using X-10 protocol
- Supports up to 32 home automation devices
- 16 automation schedules
- 8 automation modes
- Programmable through a local Touch-Tone* telephone
- All programming guided by easily understood voice prompts
- Uploading and downloading supported with DLS-3 v1.0 (Windows) downloading software packages

Specifications

- Escort4580 v1.3 will work with the PC4020 v3.1 and higher
- Connects to the PC4020 Combos and R-1 and T-1 terminals
- Nominal current draw:
 - Stand-by: 65 mA
 - Connected to local (on-premise) telephone: 150mA
 - Connected to remote (off-premise) telephone: 130 mA
- Mounts in same cabinet as PC4020

*Touch-Tone is a trademark of Stentor Resource Centre Inc.

Installation

S e c t i o n 2

Mounting the Cabinet

Install the Escort4580 on either side-wall of the PC4020 cabinet, mounted in a dry, secure location. If mounting a new cabinet for the Escort4580, select a dry location close to the already installed alarm control panel and close to the telephone connection.

To mount the unit:

1. Press the four plastic standoffs through the mounting holes on the side wall of the cabinet.
2. Hold the cabinet in position and pull all wires into the cabinet.
3. Secure the cabinet to the wall in the desired location. Use appropriate wall anchors when securing the cabinet to drywall, plaster, concrete, brick or other surfaces.
4. Press the circuit board into the plastic standoffs to secure the module to the cabinet.

Once the unit is mounted, complete the wiring.

Wiring

Before beginning to wire the unit, ensure that all power (AC transformer and battery) is disconnected from the control panel. Refer to the wiring diagram on page ii.

To wire the Escort4580:

1. Connect the four Combustion wires to the Escort4580. Connect the red, black, yellow and green Combustion wires to the RED, BLK, YEL and GRN terminals, respectively.
2. RNG and TIP Terminals
Connect the Escort4580 RNG terminal to the alarm control panel R-1 terminal.
Connect the Escort4580 TIP terminal to the alarm control panel T-1 terminal.
Connect the Escort4580 T-1 terminal to the brown (BRN) conductor of the premises telephone line.
Connect the Escort4580 R-1 terminal to the grey (GRY) conductor of the premises telephone line.

NOTE: The Escort4580 must be located after the control panel on the telephone lines. The Escort4580 will not function if connected at any other point on the telephone lines.

3. RJ-11X Connector to X10 Module

Use an RJ-11X connector and cable (not supplied) to connect the Escort4580 to an X-10 PL-513 or X-10 Pro PSC04 module. Refer to and follow the manufacturer's instructions for installing the PL-513 or PSC04 module.

The following diagram shows the required cable for connecting the Escort4580 to the PSC04 (PL513). With the jacks side by side (tabs facing up), the colors of the wire in each jack will appear in the same order from left to right. This cable is called a 'Straight Through Cable' as per telephone industry standards.

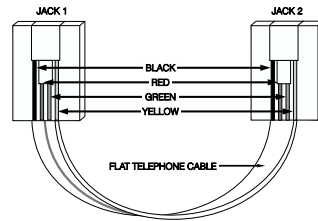

NOTE: Do not use a 'Swapped', 'Flipped' or 'Crossover' cable as it will not work with the ESCORT4580. To verify whether you have the correct type of cable, plug in the PSC04 (PL513). The red LED should turn ON. Connect the telephone cable to both the PSC04 (PL513) and the ESCORT4580. If the LED on the PSC04 (PL513) turns OFF and remains unlit, you are using the wrong type of cable.

4. Escort4580 to PC4936 Module
If you will be adding a PC4936 to the system, use the supplied cable to connect it to the Escort4580 at the dedicated audio ports on each module.

[132] Automation Item 1: Schedule Assignment

There are 16 Automation Schedules in the Escort4580 which determine the ON time, OFF time and Day Mask. Each schedule can only control an automation item in a single 24 hour period (ie. from midnight to midnight of one day). See section 6, "Automation Schedules" for information on programming the schedules. To program an item to follow a particular schedule, turn ON the option corresponding to the number of the schedule (e.g., turning ON only option 01, programs the automation item to follow only schedule number 1).

NOTE: If you need to program an automation item to be active past midnight, either:

- use multiple schedules to control the item, or
- program the automation item for (01) Follows Programmable Output Only in section [134] and use a Date Schedule in the PC4020 to control the automation item (via the Programmable Output programming). Refer to your PC4020 Installation Manual for more information.

[133] Automation Item 1: Mode Assignment

Mode assignment gives users additional control over automation items programmed for scheduled or event initiated operation. You can assign any automation item to one or more of 8 modes.

Users can turn modes on or off using the [*] [5] command. If one of the modes an item is assigned to is ON, and the Follows Schedule/Output only if a Mode is ON option (section [133]:[05]) is enabled, the automation item will only activate at the scheduled times or when an event occurs. If all of the modes an item is assigned to are OFF, the item will not activate.

Example 1: Vacation mode. If the users will be away for a period of time, they can use [*] [5] to turn on the Vacation mode. You can assign automation items such as lights and drapery to the Vacation mode. Program the schedules and programmable outputs in such a way that the premises will appear occupied. When the Vacation mode is on, the lights and drapery will activate according to the programmed schedules and programmable output options.

Example 2: Sprinkler mode. Automation item 1 is assigned to the sprinkler system. Item 1 is programmed to follow schedule 1, which activates from 1:00 am to 3:00 am every day of the week. Automation item 1 is also assigned to the Sprinkler mode. If Sprinkler mode is on, the sprinklers will turn on from 1:00am to 3:00am every day.

On rainy days the user can turn off Sprinkler mode to prevent the sprinklers from coming on. When the weather clears the user can turn on Sprinkler mode again to have the sprinklers turn on following the schedule.

NOTE: If you assign an item to more than one mode, the item follows its assigned schedules when any of its assigned modes are ON. To prevent an item assigned to more than one mode from following any of its assigned schedules, ALL the modes assigned to the item must be turned OFF.

[134] Automation Item 1: Schedule / Output Condition

Enter a 2-digit number to determine how the automation item will operate.

(00) Manual User Control Only: Users can control the item only through the [*][5] command (if section [131], option [02] is ON). The item will not follow schedules or output assignments.

(01) Follows Programmable Output Only: The item will follow the state of its assigned programmable output option. See 'Assigning Items to Programmable Outputs' below.

Example: Item 1 controls a light. If item 1 is assigned to programmable output option (07) Inverted Arm Status, the light will be on when the system is disarmed, and off when the system is armed.

(02) Follows Schedule Only: The item will follow the state of its assigned schedules. See 'Schedule Assignment' on previous page.

Example: Item 1 controls a light. If item 1 is assigned to schedule 3, which activates at 19:00 and deactivates at 22:00 every day, the light will turn on at 7:00pm and off at 10:00pm every day.

Programming

S e c t i o n 3

05 Schedule/Output Options

ON Follows Schedule / Output Condition Always. The automation item will always follow the Schedule / Output condition programmed in the Item Schedule / Output Condition programming section.

OFF Follows Schedule / Output Condition only when Mode is ON. The automation item will follow the Schedule / Output Condition only when a *mode* assigned to the item is ON. This function would be used for items that are required to selectively follow a schedule or output. A lawn sprinkler system is a typical application of this function. See [133] 'Automation Item 1: Mode Assignment' for examples of the uses of modes.

06 Duration Options

ON Item ON Steady while Active. When ON, the automation item will remain activated until it is deactivated by the user, a schedule or an Alarm System Output.

OFF Programmed Pulse when Active. When OFF, the automation item will be activated for the length of time programmed in the item's automation item Pulse Timer section (see programming sections [301] through [332]). Use this option to trigger devices requiring a trigger pulse, or to activate an item for a specific length of time.

NOTE: Do not use the 'Programmed Pulse When Active' feature if Dimming is enabled. All pulses turn the automation item ON.

07 Prompt Option 1

ON Item prompt is 'ON / OFF'. When ON, the automation item will prompt 'ON' and 'OFF' for the ON and OFF states while controlled by the [*][5] command. This prompt would be used for devices such as lights or appliances.

OFF Item prompt is not 'ON / OFF'

08 Prompt Option 2

ON Item prompt is 'OPEN / CLOSED'. When ON, the automation item will prompt 'OPEN' and 'CLOSED' for the ON and OFF states while controlled by the [*][5] command. This prompt would be used for applications such as curtains and door openers.

OFF Item prompt is not 'OPEN / CLOSED'.

09 Prompt Option 3

ON Item prompt is 'SETBACK ON / SETBACK OFF'. When ON, the automation item will prompt 'SETBACK ON' and 'SETBACK OFF' for the ON and OFF states while controlled by the [*][5] command. This prompt would be used for applications such as temperature control.

OFF Item prompt is not 'Setback ON / Setback OFF'

NOTE: Only one of Options 07, 08 and 09 should be ON. If more than one option is ON, the system will use the first enabled option. If none of the options are ON, the system will use Option 07.

With the system disarmed, perform the following to access the Escort4580 programming mode:

1. Pick up a local telephone handset. You will hear:

'Dial Tone.'

2. Enter the telephone access code. The default telephone access code is [***]. You can reprogram this code in Section [020]. The system prompts:

'Hello'

3. Enter programming mode by pressing [*][8]. The system prompts:

'Enter the Service Code'

4. Enter the 4-digit service code. The default service code is [4580]. You can change the service code in programming section [001]. After the service code is entered, the system prompts:

'Enter a Section Number. To exit, press [#]'

5. To enter a programming section, enter the 3-digit number of the section. If you make an error entering the section number, the system prompts:

'Invalid entry. Enter a Section Number. To exit, press [#]'

When you enter a section number correctly, the system announces the section you have entered with the prompt:

'Section (number)'

Programming Data Entry Sections

To program a data entry section from the Escort4580 programming mode:

1. Enter the 3-digit section number.

2. The system announces the section you have entered with the prompt:

'Section (number)'

The system announces the data presently programmed in the programming section as:

'Data is (data)'

The system then prompts:

'Enter new data'

3. Enter the new data in the section, or return to the 'Enter a Section Number' prompt, by pressing [#]. When you have finished entering the new data, the system announces the new data with the prompt:

'Data is (data)'

If you make an invalid data entry, the system announces:

'Invalid Entry. Data is (data). Enter new data'

4. Record the new data in the appropriate section of the *Programming Worksheets*.

Automation Items

S e c t i o n 7

Programming Toggle Option Sections

To program a section with toggle options from the Escort4580 programming mode:

1. Enter the 3-digit section number.
2. The system announces the section you have entered with the prompt:

'Section (number)'

The system announces which options are presently turned ON with one of the following prompts:

'All options are off'

'All options are on'

'Option (number) is on'

'Options (numbers) are on'

The system then prompts:

'Enter two digit option. To Exit, press pound'

3. To exit the section without making any changes, press [#].

To turn an option ON or OFF, enter the 2-digit option number.

If you enter an invalid option number, the system prompts:

'Invalid entry'

After you enter a valid option number, the system again announces which options are ON.

4. When you have finished programming the options in the section, press [#]. The system returns to the 'Enter a Section Number' prompt.
5. Record your new programming choices in the appropriate section of the *Programming Worksheets*.

Programming Label Entry Sections

To program or change a label:

1. Enter the section number of the label. The system announces the section number and then recites the words presently programmed in the label. Each label may have up to six words, except for zone labels which may have up to eight words.

NOTE: *The first two words in a zone label will only be announced when the zone is in alarm.*

The system then prompts:

'Enter three digit word. To exit, press pound'

2. Enter the first word of the label using the 3-digit codes from the Label Library in Appendix B of the *Programming Worksheets*.

The system beeps at the end of each correctly entered code and the system prompts:

'Enter three digit word. To exit press pound'

If you make an invalid entry, the system prompts:

'Invalid entry. Enter three digit word. To exit press pound'

3. If you have more words to program, enter the 3-digit code of each word until you are finished.
4. When you have entered the maximum number of words, the system will recite the label. If your label is less than the maximum number of words, press [#].
5. To have the system read the new label to you, enter the programming section for the label again.
6. If the label is correct, press [#]. To change the label again, repeat steps 1-5, above.
7. Record the new label in the appropriate section of the *Programming Worksheets*.

See section 8, "Label Programming" for more information on how to program labels.

When you have completed all programming, hang up the handset.

An automation item is an object (usually an appliance, such as a light) that can be controlled (turned on or off, or dimmed) by the Escort4580. For automation items to work, you need to enable the Home Automation feature in section [002], option [01], in addition to the programming described in this section.

Program the operation of automation items 01 - 32 in programming sections [130] through [289]. You need to program five sections to describe the operation of each automation item:

- Program the home automation item House Code and Unit Number
- Program various operating options as described below
- Program a schedule for the automation item to follow
- Program a mode for the automation item to follow
- Program the output condition of the automation item

Programming sections [130] through [134] for automation item 01 are described in detail below. The programming sections for automation items 02 through 32 are programmed in the same manner.

To assign an automation item to a programmable output option, see *Assigning Items to Programmable Outputs* at the end of section 7.

[130] Automation Item 1: House Code and Unit Number

Program an X-10 protocol House Code and Unit Number for the automation item. Enter a 3-digit number from *Programming Worksheets Appendix A*, 'X-10 Protocol House Code and Unit Numbers'.

[131] Automation Item 1: Miscellaneous Options

01 Item Options

- ON Automation Item Enabled.
- OFF Automation Item Disabled.

02 User Control Options

- ON User Controlled ON/OFF. When ON, the user will be able to use the [*][5] command to turn the automation item on or off.
- OFF Not User Controlled. When OFF, users will not be able to use the [*][5] command to turn the automation item on or off. The item may still be controlled by a schedule or programmable output. See [134] Automation Item 1: Schedule / Output Condition for more information.

03 Global ON/OFF Options

- ON Included in Global ON/OFF Command. When ON, the automation item will turn ON or OFF when a user executes the Global Item Control function from the [*][5] command. For this option to work, option (01) User Controlled ON/OFF must be on as well.
- OFF Not included in Global ON/OFF Command. When OFF, the automation item will not be affected by the Global Item Control function.

04 Dimming Options

- ON Dimming Enabled. When ON, the user can select any of 6 dimming states for the automation item: ON, OFF, and Levels 1 through 4. Only use this option for lights or other items connected to power line modules capable of dimming.
- OFF Dimming Disabled. When OFF, the user can only select ON or OFF for the automation item.

Automation Schedules

S e c t i o n 6

Program schedules for controlling automation items in sections [030] - [077]. You need to program 3 programming sections for each schedule:

- ON Time
- OFF Time
- Day(s) of the week (Day Mask)

The ON and OFF times must occur within the same 24-hour period (that is, within the same day), unless multiple schedules are used. In the ON time and OFF time sections, enter a time in the 24-hour format. Valid entries are 00 to 23 for the hour, and 00 to 59 for the minute. Refer to section 3, "Programming" for instructions on how to program data sections.

In the Day Mask section, select the days of the week the schedule will activate on by turning the appropriate options ON or OFF. Refer to section 3, "Programming" for instructions on how to program the toggle option sections.

The following describes the programming sections for Schedule 1:

[030] Schedule 1 ON Time

This section determines the time Schedule 1 will turn ON. Enter a 4-digit time in the 24-hour clock format. Valid entries are from 00 to 23 for the hour, and 00 to 59 for the minute.

[031] Schedule 1 OFF Time

This section determines the time Schedule 1 will turn OFF. Enter a 4-digit time in the 24-hour clock format. Valid entries are from 00 to 23 for the hour, and 00 to 59 for the minute.

[032] Schedule 1 Day Mask

This section determines the days on which Schedule 1 will function. Enter the 2-digit option number to turn each day ON or OFF.

Option	ON	OFF
01	Sunday ON	Sunday OFF
02	Monday ON	Monday OFF
03	Tuesday ON	Tuesday OFF
04	Wednesday ON	Wednesday OFF
05	Thursday ON	Thursday OFF
06	Friday ON	Friday OFF
07	Saturday ON	Saturday OFF

NOTE: Program schedules 2 through 16 in sections [033] to [077].

System Programming

S e c t i o n 4

[001] Service Code

The service code allows access to the Escort4580 programming sections. Enter a 4-digit code in this section. The default service code is [4580].

[002] First System Option Code Option

01	ON	Home Automation enabled.
	OFF	Home Automation disabled. When disabled, the automation items will not work.
02	ON	[*][5] Automation Control command requires an access code. The system will require users to enter a valid access code before they can access automation items.
	OFF	[*][5] Automation Control command does not require an access code.
03	ON	When this option is enabled, the Escort4580 transmits to automation items on the system with the timing parameters required for 50Hz operation . Use this option if the AC in the building is 50Hz.
	OFF	The timing for 60Hz operation will be used for automation items. Use this option if the AC in the building is 60Hz.

[003] Status Prompt Mask

This section determines which Status prompts the user will hear. If an option is 'ON', the system will announce the prompt when the appropriate condition is present. If an option is 'OFF', the system will not announce the prompt if the condition is present.

Option

01	ON	' Warning, Bypass On ' prompt enabled
	OFF	Disabled
02	ON	' System Open, Zone X ' prompt enabled
	OFF	Disabled
03	ON	' Alarms in Memory ' prompt enabled
	OFF	Disabled
04	ON	' AC Trouble ' prompt enabled
	OFF	Disabled
05	ON	' Phone Line Trouble ' prompt enabled
	OFF	Disabled
06	ON	' Low Battery on Zone X ' prompt enabled
	OFF	Disabled
07	ON	' Loss of Clock Trouble ' prompt enabled
	OFF	Disabled
08	ON	' System Fault, Service Required ' prompt enabled
	OFF	Disabled
09	ON	' For More Options, Press Star ' prompt enabled
	OFF	Disabled
10	ON	' System On Without Entry Delay ' prompt enabled
	OFF	Disabled
11	ON	' Automation Service ' prompt enabled
	OFF	Disabled
12	ON	' Zone Tamper ' prompt enabled
	OFF	Disabled
13	ON	' Zone Fault ' prompt enabled
	OFF	Disabled
14	ON	' Warning, System Trouble ' prompt enabled
	OFF	Disabled

Telephone Access Programming

S e c t i o n 5

[004] [*] Function Prompt Mask

This section determines which [*] function prompts the user will hear. When 'ON', the system will announce the prompt. When 'OFF', the system will not announce the prompt. Users can still use [*] functions even if the prompt is turned off.

Option

- 01 ON 'For Zone Bypassing' prompt enabled
OFF Disabled
- 02 ON 'For Alarm Memory' prompt enabled
OFF Disabled
- 03 ON 'For Door Chime Control' prompt enabled
OFF Disabled
- 04 ON 'For Automation Control' prompt enabled
OFF Disabled
- 05 ON 'For Special Functions' prompt enabled
OFF Disabled
- 06 ON 'For Output Control' prompt enabled
OFF Disabled
- 07 ON 'For Arming Without Entry' prompt enabled
OFF Disabled
- 08 ON 'For Quick Arming' prompt enabled
OFF Disabled
- 09 ON 'For Quick Exit' prompt enabled
OFF Disabled
- 10 ON 'To Arm Interior Zones' prompt enabled
OFF Disabled
- 11 ON 'For System Troubles' prompt enabled
OFF Disabled

[005] Local Programming Lockout Counter

The Local Programming Lockout feature prevents Escort4580 access after a programmable number of invalid access codes are entered on a handset. Enter the number of invalid codes to be allowed before Local Programming Lockout is activated. Valid entries are between 000 and 255. The default setting is 000.

[006] Local Programming Lockout Duration

Program the amount of time, in minutes, that the Local Programming Lockout will last. During the Local Programming Lockout Duration, the Escort4580 will not accept any access code, even valid access codes. Enter a time between 000 to 255 minutes. The default setting is 000.

[007] Number of Home Automation Transmissions

Program the number of Home Automation ON or OFF commands that will be transmitted when a home automation item is activated. Multiple ON / OFF commands may be used to ensure more reliable control of automated devices. Valid entries are 001 to 255, the default setting is 001.

[010] - [017] Output Control Prompt Masks By Partition

Enable or disable the prompts for Command Outputs 1-8 for each partition. See your PC4020 *Installation Manual* for more information on command outputs.

[020] Local and Remote Telephone Access Code

This 3-digit code allows access to the system through a telephone on the premises, or from a remote phone. The default telephone access code is [***]. Enter a 3-digit code using the numbers 0 through 9, and/or the signs [#] and [*].

Important Note: Avoid programming a telephone access code that coincides with 3-digit local telephone numbers and services. In most areas, 0xx, 411, 911 and 611 should not be used as a telephone access code. Also, in some areas, telephone services may be available by dialling [*] and 2 digits. Ensure that the telephone access code is not the same as any of the [*] functions available from the service provider.

[021] Telephone Access Options

- 01 ON Remote Access Enabled. The user will be able to access the system from remote Touch-Tone telephones. To gain access to the system, the user must call the system and hang up after one or two rings. The user then calls the system again. When the system answers the call, enter the telephone access code to access the system.
- OFF Remote Access Disabled. The system will not allow access from off-premises telephones.

NOTE: Remote Access must be disabled on UL Listed products.

NOTE: To enable Escort4580 remote access, you must also turn on the **DLS Enabled** toggle option in the **DLS Toggles** section (reference number [000300]) of the PC4020 control panel.

- 02 ON Access Code Always Required for Local Access. When the user picks up a premises telephone and enters the (3-digit) telephone access code, the system will require that a valid (4- or 6-digit) access code be entered.
- OFF No Access Code Required for Partition Access. When the user picks up a premises telephone and enters the (3-digit) telephone access code, the Escort4580 provides immediate access to the system.